

FOR EMC/MICROWAVE ANECHOIC CHAMBERS

IP MATERIAL

A composite electromagnetic absorber made by combining the IP electromagnetic absorber, which consists of a styrofoam base and utilizes the ohmic loss of carbon, and an electromagnetic absorber that uses the magnetic loss of ferrite.

These composite absorbers fully utilize the features of each loss material. In ranges of 500MHz or lower the IB electromagnetic absorbers, and in the higher range of 500MHz and higher the IP electromagnetic absorbers, are designed to provide efficient electromagnetic absorption.

IP-045E

TDK composite electromagnetic absorbers praised highly for their application in EMC/microwave tests.

IP-045E delivers excellent electromagnetic absorption performance for vertical incidences starting at 30MHz to the microwave range.

Additionally, our line up includes IP-100C and IP-150C that deliver excellent electromagnetic absorption performance starting at low frequency ranges. These are optimally suited for six-sided anechoic chambers (for EN and ETSI compliance).



FEATURES

- Ultra-wideband electromagnetic absorber.
- Stable against acids, bases and water vapor, and offers long service life.
- Uses materials that, when burned, emit gases that are relatively harmless to humans.
- Fire retardant (NRL Classes 1, 2 and 3; UL-94HBF).

PRODUCT IDENTIFICATIONS

I P - 100 C
 (1) (2) (3) (4)

- (1) TDK electromagnetic absorbers
- (2) Base material code (P: Styrofoam)
- (3) Length dimensional code (100: 100cm)
- (4) Version code

SHAPES AND DIMENSIONS

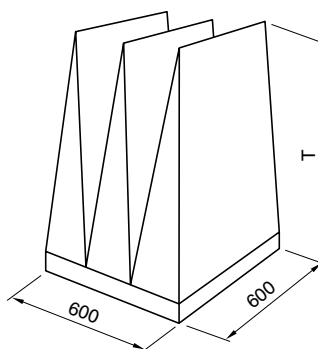

Dimensions in mm

STANDARD MATERIALS

Material name	Length (cm)	Standard weight* (kg)	Applicable anechoic chambers
IP-045E	45	3	EMC and antenna evaluation etc.
IP-100C	100	6	EN and ETSI compliant
IP-150C	150	8.5	EN and ETSI compliant

* Not including the mass of ferrite

TYPICAL ABSORPTION CHARACTERISTICS (VERTICAL INCIDENCE)

Unit: dB

Material name	30MHz	50MHz	100MHz	500MHz	1GHz	5GHz	18GHz	40GHz
IP-045E	14	14	14	20	30	40	40	40
IP-100C	17	17	18	25	30	40	40	40
IP-150C	20	23	30	30	32	40	40	40

- 200v/m Can be applied to EMS tests